

**Spectrophotometric  
underway pH  
determination**

S. Aßmann et al.

This discussion paper is/has been under review for the journal Ocean Science (OS).  
Please refer to the corresponding final paper in OS if available.

# Spectrophotometric high-precision seawater pH determination for use in underway measuring systems

**S. Aßmann<sup>1</sup>, C. Frank<sup>1</sup>, and A. Kötzinger<sup>2</sup>**

<sup>1</sup>Helmholtz-Zentrum Geesthacht, Institute of Coastal Research, Max-Planck-Str. 1,  
21502 Geesthacht, Germany

<sup>2</sup>Leibniz Institute of Marine Sciences, Marine Biogeochemistry, Düsternbrooker Weg 20,  
24105 Kiel, Germany

Received: 27 May 2011 – Accepted: 30 May 2011 – Published: 14 June 2011

Correspondence to: S. Aßmann (steffen.assmann@hzg.de)

Published by Copernicus Publications on behalf of the European Geosciences Union.

[Title Page](#)

[Abstract](#)

[Introduction](#)

[Conclusions](#)

[References](#)

[Tables](#)

[Figures](#)



[Back](#)

[Close](#)

[Full Screen / Esc](#)

[Printer-friendly Version](#)

[Interactive Discussion](#)



## Abstract

Autonomous sensors are required for a comprehensive documentation of the changes in the marine carbon system and thus to differentiate between its natural variability and anthropogenic impacts. Spectrophotometric determination of pH – a key variable of the seawater carbon system – is particularly suited to achieve precise and drift-free measurements. However, available spectrophotometric instruments are not suitable for integration into automated measurement systems (e.g. FerryBox) since they do not meet the major requirements of reliability, stability, robustness and moderate cost. Here we report on the development and testing of a new indicator-based pH sensor that meets all of these requirements. This sensor can withstand the rough conditions during long-term deployments on ships of opportunities and is applicable on the open ocean as well as in coastal waters with complex background and highly variable conditions. The sensor uses a high resolution CCD spectrometer as detector connected via optical fibers to a custom-made cuvette designed to reduce the impact of air bubbles. The sample temperature can be precisely adjusted ( $25^{\circ}\text{C} \pm 0.006^{\circ}\text{C}$ ) using computer-controlled power supplies and Peltier elements thus avoiding the widely used water bath. The overall setup achieves a measurement frequency of  $1 \text{ min}^{-1}$  with a precision of  $\pm 0.0007$  pH units and an average offset of  $+0.0018$  pH units to a pH reference during shipboard operation. Application of this sensor allows monitoring of seawater pH in autonomous underway systems, providing a key variable for characterization and understanding the marine carbon system.

## 1 Introduction

The pH of seawater is one of the four measurable variables to analytically determine the parameters of the seawater  $\text{CO}_2$  system (Millero, 2007). It has been shown that the pH of the surface ocean is decreasing by about 0.0019 pH units per year (Dore et al., 2009) as a consequence of  $\text{CO}_2$  uptake under the increasing atmospheric  $\text{CO}_2$  concentration.

OSD

8, 1339–1367, 2011

## Spectrophotometric underway pH determination

S. Aßmann et al.

Title Page

Abstract

Introduction

Conclusions

References

Tables

Figures

⏪

⏩

◀

▶

Back

Close

Full Screen / Esc

Printer-friendly Version

Interactive Discussion



## Spectrophotometric underway pH determination

S. Aßmann et al.

Title Page

Abstract

Introduction

Conclusions

References

Tables

Figures

◀

▶

◀

▶

Back

Close

Full Screen / Esc

Printer-friendly Version

Interactive Discussion



The oceanic sink for anthropogenic CO<sub>2</sub> amounts to approx. 48 % (Sabine et al., 2004) of the entire cumulative emissions. This phenomenon, also known as ocean acidification (Doney et al., 2009), may have significant effects on marine ecosystems and has become a major research area. To adequately document natural variability a high temporal and spatial resolution of high quality pH measurements is needed. Therefore there is a large interest to include CO<sub>2</sub> system parameters as standard parameter during ship cruises and on monitoring stations. Especially in coastal areas these monitoring devices have to be very robust to withstand rough environmental conditions as well as rapid changes of the composition of the water body.

For the measurement of seawater pH different approaches are described in literature. The most promising approach for pH determination are spectrophotometric measurements employing an indicator dye, refined by Clayton and Byrne (1993). Using glass electrodes for potentiometric pH determination of seawater is critical because accuracy can not be assured to be better than ±0.01 pH units (SCOR Working Group 75, 1988), which is critical for carbon-system calculations. However, another promising approach is the application of Durafets (ion sensitive field effect transistor based pH sensors) tested by Martz et al. (2010).

The spectrophotometric method uses an indicator dye with an appropriate and precisely known pK<sub>a</sub> value and acceptable extinction coefficient ratios of the basic and acidic form. The robustness of this method lies in the potential stability of such a system, which relies only on the accurate measurement of salinity and temperature thereby circumventing all problems associated with the calibration of such a system. It has been realized successfully in various designs and applications. Many designs already focus on in-situ applications like profiling and moorings (Martz et al., 2003; Liu et al., 2006; Nakano et al., 2006; Seidel et al., 2008) and also on underway systems (Bellerby et al., 2002). These instruments measure the pH at in-situ temperature and thus have to use the thymol blue indicator whose pK<sub>a</sub> value is known over a large temperature range (Zhang and Byrne, 1996). However, due to the slight mismatch of the indicator range of thymol blue and of the natural seawater pH range, this indicator dye

is not as well suited for the use in coastal waters as *m*-cresol purple (mCP). In contrast the  $pK_a$  of mCP is not specified over a large temperature range which can be extended using the van't Hoff equation which has to be validated for example with a bench-top spectrometer (Seidel et al., 2008). Another approach is to use mCP and adjust the temperature of the sample to 25 °C and circumvent the problem of the limited temperature range as demonstrated by Friis et al. (2004). Friis however used a water bath to adjust the temperature of the sample and had to cope with all problems connected to maintaining and transporting such a bath.

These designs are not suitable for the integration into an automated water measurement system like the FerryBox (Petersen et al., 2003). This system is commonly used in coastal regions which can have large changes in water temperature and a wide range of pH values due to e.g. high primary production. The FerryBox devices are usually built into voluntary observing ships (VOS) and have to operate under highly varying conditions without user interaction.

The system described here uses mCP as pH indicator and finely adjusts the sample temperature to 25 °C using Peltier elements. The system design is simple and has proven to be very robust against changing environmental conditions as well as changes in the water composition and sediment load. Additionally the non-linearity of the CCD spectrometer is compensated using a technique similarly to Salim et al. (2011).

## 2 Theory

Three different seawater pH scales are used in literature, the “free”, “total” and “seawater” scale. The difference between these scales refers to the seawater model employed. Details can be found in Dickson (1984) and Zeebe and Wolf-Gladrow (2001). Measured pH values on one scale can be recalculated to another scale under certain boundary conditions. In this work the total scale is used as it is widely used in the CO<sub>2</sub> community and therefore absolute values are comparable. The formal definition of the

### Spectrophotometric underway pH determination

S. Aßmann et al.

Title Page

Abstract

Introduction

Conclusions

References

Tables

Figures



Back

Close

Full Screen / Esc

Printer-friendly Version

Interactive Discussion



total scale is given by the following equation:

$$[\text{H}^+]_{\text{T}} = [\text{H}^+]_{\text{F}} \left( 1 + \frac{S_{\text{T}}}{K_{\text{S}}} \right) \quad (1)$$

$$[\text{H}^+]_{\text{T}} \approx [\text{H}^+]_{\text{F}} + [\text{HSO}_4^-] \quad (2)$$

where  $S_{\text{T}}$  is the total sulfate concentration,  $K_{\text{S}}$  is the second dissociation constant of sulfuric acid and  $[\text{HSO}_4^-]$  represents the hydrogen sulfate ion concentration.

Spectrophotometric pH determination is based on the second dissociation reaction of the diprotic sulfonephthalein indicator dye meta-cresol purple,



where  $\text{HI}^-$  and  $\text{I}^{2-}$  are the protonated and unprotonated forms of the two indicator species and  $pK'_a$  is the second apparent dissociation constant of the dye. The indicator mCP was chosen due to its good match of the indicator range 7.4 to 9.0 (Milne, 2005) and the pH range 7.5 to 8.5 present in natural seawater (Raven et al., 2005). The  $pK'_a$  is a function of temperature  $T$  and salinity  $S$ ,

$$pK'_a = \frac{1245.69}{T/\text{K}} + 3.8275 + 0.00211(35 - S) \quad (4)$$

and valid for temperatures in the range from 293 K to 303 K and salinities from 30 to 37 psu (Clayton and Byrne, 1993). DelValls and Dickson (1998) suggested to correct the  $pK'_a$  for 0.0047 pH units, because the calibration of mCP is based on measurements made by Ramette et al. (1977) which were found to be in error. This was not done here. We refer to current literature (Dickson et al., 2007) where this addition is not included.

The pH of seawater can be calculated using:

$$\begin{aligned} \text{pH}_{\text{T}} &= -\log_{10} [\text{H}^+]_{\text{T}} \\ &= pK'_a + \log_{10} \left( \frac{R - e_1}{e_2 - R \cdot e_3} \right), \end{aligned} \quad (5)$$

where  $R$  is the absorbance ratio  $A_{578}/A_{434}$  corresponding to the peak maximum wavelengths 578 nm and 434 nm of the indicator species  $I^{2-}$  and  $HI^-$ .  $e_i$  are the ratios of the molar extinction coefficients  $\varepsilon$  (Dickson et al., 2007) as defined below:

$$e_1 = \frac{\varepsilon_{578}^{HI^-}}{\varepsilon_{434}^{HI^-}}, \quad e_2 = \frac{\varepsilon_{578}^{I^{2-}}}{\varepsilon_{434}^{HI^-}}, \quad e_3 = \frac{\varepsilon_{434}^{I^{2-}}}{\varepsilon_{434}^{HI^-}}, \quad (6)$$
$$e_1 = 0.00691, \quad e_2 = 2.2220, \quad e_3 = 0.1331.$$

To calculate the absorbance ratio  $R$ , the raw spectrophotometric data are corrected for stray light and non-linearity of the CCD detector / AD-converter (see Sect. 3.5). Furthermore the pH perturbation resulting from the addition of indicator dye solution is corrected for (see Sect. 3.5).

## 3 Materials and methods

### 3.1 System design and sample handling

The setup presented here is a bench-top system which consists of a syringe pump, a heat exchange system, a cuvette composed of polyethylene terephthalate (PET), a control and data logging unit and the optical system (Fig. 1).

The liquid handling is performed by a peristaltic pump (ISMATEC, ISM597D) to ensure a continuous, stable flow and a syringe pump (Hamilton, PSD/2) for accurate injection of the indicator. All tubings, which are in contact with sample water are not smaller than 1 mm i.d. preventing obstruction of the sample flow due to particles (e.g. in coastal waters). A gas tight plastic bag with an aluminum coating (Calibrated Instruments, Cali5Bond) is used as indicator reservoir (IR). The indicator stock solution consists of 2 mmol kg<sup>-1</sup> mCP sodium salt (Sigma Aldrich, 211761) in a 0.7 mol kg<sup>-1</sup> NaCl (Merck, 106404) solution (ionic strength  $I = 0.7$ ) to keep the equilibrium constants of the carbon system nearly undisturbed. An injection of 112.5  $\mu$ L indicator stock solution by

## Spectrophotometric underway pH determination

S. Aßmann et al.

Title Page

Abstract

Introduction

Conclusions

References

Tables

Figures

◀

▶

◀

▶

Back

Close

Full Screen / Esc

Printer-friendly Version

Interactive Discussion



the indicator pump (IP) into the continuous sample flow of approx.  $10 \text{ mL min}^{-1}$  results in an indicator concentration of up to  $115 \mu\text{mol kg-soln}^{-1}$ . This equates to absorbance values up to 0.9 at the isosbestic point of the dye (487.6 nm) and to absorbance values up to 1.8 at the indicator maximums (434 nm, 578 nm). While a non-linear behavior of the absorbance above 1.4 is possible, no such effects were observed here. Mixing of indicator dye and sample is realized by injecting the indicator solution through a tight Y-piece (YP) followed by a static mixer (piece of tubing filled with glass balls). Due to the laminar flow it is very important to place the mixer near to the cuvette to ensure a homogeneous solution in the optical path.

The seawater sample is provided by an automated water measurement system called FerryBox (Petersen et al., 2003) which is fed with a continuous flow of seawater from the clean seawater pump of the vessel. The seawater stream passes a T-piece and ends up in an open outflow to waste. The other end of the T-piece is connected to the peristaltic pump (PP).

After indicator aspiration and injection the sample flows through a stainless steel tube (3 mm o.d.) embedded in an aluminum body which is kept at  $25^\circ\text{C}$  (heat exchanger). The sample then passes the static mixer and enters the cuvette. The cuvette is made of black PET containing a typical Z-type optical path with an additional interface for a temperature sensor (Fig. 2). This sensor is used to regulate the temperature of the sample in the cuvette and also to correct the  $\text{p}K'_a$  of mCP. In order to avoid bubble formation, the waste tube ends about 1 m higher than the outlet of the cuvette thus providing a constant backpressure. An additional check valve was needed to eliminate pressure changes due to the movement of the ship (caused by the swell of the sea). The overall setup has an internal volume of about 13 mL of which the cuvette contains about 0.2 mL.

### 3.2 Temperature control

The temperature control of the sample flow is realized by means of a heat-exchange unit. Peltier elements are used to adjust the temperature of a custom-made aluminum

## Spectrophotometric underway pH determination

S. Aßmann et al.

Title Page

Abstract

Introduction

Conclusions

References

Tables

Figures

⏪

⏩

◀

▶

Back

Close

Full Screen / Esc

Printer-friendly Version

Interactive Discussion



body with an embedded steel tube. For temperature detection a calibrated temperature sensor (Jumo, Pt100 model PG 1.2812.1) is mounted in the cuvette. The temperature sensor is connected to a high precision signal amplifier and AD converter unit from Sea & Sun (custom model). This combination was calibrated to an accuracy of better than 0.01 °C using a freshly calibrated temperature reference sensor from Sea & Sun (custom model). Peltier elements (Reichelt, TECB 13) excited by a programmable power supply (PeakTech, 1885) are used to provide the necessary heating or cooling. The necessary change of polarity is accomplished by a simple custom-made electronic circuit.

Once the sample flow is stable, the temperature fluctuation of the sample inside the cuvette was found to be 25 °C ± 0.006 °C (1σ). Data from a period of six days are shown in Fig. 3.

### 3.3 Optical design

For optical measurements an ultra-bright white LED (PerkinElmer, LED Fiber Optic Illuminator, OTFI-0100) with a lifetime of 25 000 h is used as light source (LS). This light source has proven to be very stable. Therefore short-term fluctuations of the light intensity can be ruled out.

A 2048 pixel CCD spectrometer (Hamamatsu, C10082CAH) with a numerical aperture of 0.11, a slit width of 10 μm and a spectral response in the range between 200 and 800 nm is used as detector. The accuracy of the wavelength calculation polynomial and the optical resolution were determined in advance using a bench-top spectrometer (PerkinElmer, Lambda 950) in the laboratory. In contrast to CCD spectrometers from other manufacturers, a very good wavelength – pixel assignment and a spectral resolution of approx. 1 nm FWHM (Full Width Half Maximum) were determined over the entire spectrum.

## Spectrophotometric underway pH determination

S. Aßmann et al.

Title Page

Abstract

Introduction

Conclusions

References

Tables

Figures



Back

Close

Full Screen / Esc

Printer-friendly Version

Interactive Discussion





Custom-engineered optical fibers from Ocean Optics (1 m length, 1000  $\mu\text{m}$  diameter optical fiber bundle) are used in this setup. The optical fibers reach about 5 mm into the optical path of the cuvette thus avoiding problems caused by air bubbles (Fig. 2). This is an important prerequisite for precise and accurate measurements (Martz et al., 2003).

### 3.4 Electronics and software

The entire setup was controlled by in house software written in the python programming language (van Rossum, 1995). It is based on software already described by Frank and Schroeder (2007). The software consists of three small programs and one slightly larger program which communicate with each other (using network sockets). The small programs each communicate with one external device (2 $\times$  programmable power supply, 1 $\times$  temperature unit, 1 $\times$  custom-made electronic circuit) of which one also accounts for the temperature regulation of the heat exchanger. The main program controls the whole setup.

During data collection a pre-calculated pH value is estimated assuming a salinity of  $S = 35$ . The final result is calculated later using the salinity measured either by an on board thermosalinograph or the salinity sensor of the FerryBox.

### 3.5 Calculation procedure

A series of dark spectra is taken prior to every 100 measurement sequences and its average is subsequently subtracted from all other spectra. The dark spectrum only depends on the temperature of the diode array of the CCD spectrometer which is held at constant temperature.

Even though the light source is very stable, a baseline spectrum was recorded prior to each measurement cycle to compensate for lamp aging as well as for changes of the optical properties of the seawater sample. Fifty baseline spectra are recorded and averaged simultaneously with the indicator injection into the sample flow. With

## Spectrophotometric underway pH determination

S. Aßmann et al.

Title Page

Abstract

Introduction

Conclusions

References

Tables

Figures

⏪

⏩

◀

▶

Back

Close

Full Screen / Esc

Printer-friendly Version

Interactive Discussion



Discussion Paper | Discussion Paper | Discussion Paper | Discussion Paper | Discussion Paper

an integration time of 10 ms, recording the baseline takes less than a second. The spectrum of the lamp taken during shipboard operation is shown in Fig. 4.

For pH calculations three wavelengths are used. The  $\text{HI}^-$  and  $\text{I}^{2-}$  maximums are detected at 578 nm and 434 nm for calculating the pH value using Eq. (5). The isosbestic point is detected at 487.6 nm which is used for the correction of the perturbation of the seawater sample caused by the indicator injection.

After subtraction of the dark spectrum the three light intensities at the mentioned wavelengths are estimated from the raw data of the spectrometer. Therefore a polynomial best-fit curve through the intensities of the adjacent pixels in the range of  $\pm 10$  nm around each of the three mentioned wavelengths is calculated. Interpolation due to the generated polynomial permits the calculation of the light intensity at the precise wavelength. This approach also compensates for electric noise on the pixels of the CCD spectrometer.

Another important step of raw data treatment is the compensation of non-linearity of the CCD sensor as well as the 16 bit A/D converter inside the spectrometer for each pixel. The polynomial used to correct for this non-linearity was gained from experiments with the same spectrometer in advance. This was done by taking spectra at different integration times. As the light source is very stable the intensity should be directly proportional to the integration time. Any deviation from this behavior was used to generate the mentioned polynomial. The magnitude of the non-linearity increases with intensity. At 30 000 counts an addition of 1044 counts is needed to maintain linearity. Hence a correction for non-linearity is indispensable. Stray light inside the spectrometer which is compensated by this correction to a certain degree is neglected. Its maximum magnitude was found to be 50 counts resulting in a pH offset of less than  $-0.0004$ .

After these corrections the data can be used for the pH calculation procedure. The absorbance ( $A_\lambda$ ) calculation procedure is given in Eq. (7).

$$A_\lambda = \log_{10} \left( \frac{I_\lambda^0}{I_\lambda} \right). \quad (7)$$

## Spectrophotometric underway pH determination

S. Aßmann et al.

[Title Page](#)[Abstract](#)[Introduction](#)[Conclusions](#)[References](#)[Tables](#)[Figures](#)[⏪](#)[⏩](#)[◀](#)[▶](#)[Back](#)[Close](#)[Full Screen / Esc](#)[Printer-friendly Version](#)[Interactive Discussion](#)

$I_\lambda$  and  $I_\lambda^0$  are the intensities at the wavelength  $\lambda$  of the sample and the baseline spectrum. No correction for baseline drift is necessary due to the high lamp stability and the high frequency of baseline measurements which take place prior to every indicator dye injection. Moreover in this setup no significant intensities above 690 nm are available, because of the limitations in the spectrum of the lamp (see Fig. 4).

The influence of the addition of indicator solution on the sample pH can be estimated using different indicator concentrations (Clayton and Byrne, 1993; Zhang and Byrne, 1996). In this case an indicator concentration gradient is induced by the injection of a small amount (approx. 100  $\mu\text{L}$ ) of indicator stock solution by the IP into the continuous sample flow, similar to Seidel et al. (2008). The generated dilution curve (Fig. 5) is moving through the cuvette and the spectra are recorded. With an integration time of 10 ms more than 200 spectra are available for the indicator correction. The pH of each spectrum was calculated and a linear regression of pH vs.  $A_{487.6}$  was performed (Fig. 6). During that process outliers are removed. Every pH value with a residual larger than  $6\sigma_e$  ( $\sigma_e$ : standard error of estimate of the linear regression) is removed which affects about 1% of the pH values during one indicator stroke. The error of the perturbation-free pH value (axis intercept) during one measurement amounts to  $\pm 0.0002$  ( $1\sigma$  of intercept of linear regression of pH vs.  $A_{487.6}$ ).

The pH value of the indicator stock solution was roughly adjusted to  $\text{pH}_{\text{NBS}} = 8.2$  with HCl/NaOH in the laboratory using a glass electrode to keep the perturbation of the sea-water sample as small as possible. At a  $\text{pH}_T = 8.1067$  of the sample the perturbation amounts up to 0.004 pH units.

## 4 Results and discussion

### 4.1 Precision and accuracy

The system described here is aimed for but not limited to the integration into a well-established autonomous measurement system such as the FerryBox (Petersen et al.,

## Spectrophotometric underway pH determination

S. Aßmann et al.

Title Page

Abstract

Introduction

Conclusions

References

Tables

Figures

◀

▶

◀

▶

Back

Close

Full Screen / Esc

Printer-friendly Version

Interactive Discussion



2005). These autonomous systems are usually placed on platforms such as VOS, buoys or on-shore stations. These measurement systems can only be serviced once a week or less. Under such conditions robustness and reliability are important prerequisites for all integrated and attached sensors and analyzers. Further requirements are portability, size and weight of the device. These preconditions have an impact on the design of the system and therefore on its precision and accuracy. To estimate the system's precision and accuracy as well as its robustness, several tests have been carried out on board research vessels of which an excerpt is provided here.

To determine the accuracy of the system, a TRIS buffer provided by Scripps Institution of Oceanography in La Jolla/California (Batch 6:  $\text{pH} = 8.0893 \pm 0.0009$ ) was used as certified reference material (CRM). Comparative measurements were made with a bench-top spectrometer (PerkinElmer, Lambda 950) in the laboratory where the pH of the CRM was found to be  $8.0969 \pm 0.0004$  pH units. The difference of 0.0076 pH units can be explained with impurities in the indicator dye which can cause offsets of up to 0.01 pH units (Yao et al., 2007; Liu et al., 2011). The measured pH of the underway pH-system was found to be  $8.0987 \pm 0.0012$ . The average offset compared to the bench-top spectrometer is 0.0018 pH units which is slightly outside the error bars.

The precision and the average offset of the underway system compared to the bench-top spectrometer are relatively high. This is most likely caused by the very small sample bottles of the CRM which make it rather complicated to generate a stable homogeneous flow with constant temperature. The system needs some time (approx. 5 min) for the temperature control to be stable to within  $\pm 0.006^\circ\text{C}$ . Once the temperature regulation is stable, the short-term precision of subsequent measurements of TRIS buffer according to Dickson et al. (2007) decreases to  $\pm 0.0007$  pH units (see Fig. 7). The long-term precision was not determined here but is expected to be less than 0.001 pH units (Dickson, 1993).

For a comprehensive evaluation of accuracy of this system additional carbon system parameters such as total dissolved inorganic carbon (DIC), total alkalinity (TA) or  $\text{CO}_2$  fugacity ( $f\text{CO}_2$ ) are required to obtain an overdetermined system for cross validation.

## Spectrophotometric underway pH determination

S. Aßmann et al.

Title Page

Abstract

Introduction

Conclusions

References

Tables

Figures



Back

Close

Full Screen / Esc

Printer-friendly Version

Interactive Discussion



Wang et al. (2007) has introduced such a system with three carbon parameters achieving a good internal consistency.

## 4.2 Underway measurements

Underway measurements were performed during the R/V *Polarstern* cruises ANT-XXVI/1 (November 2009) and ANT-XXVI/4 (May 2010) over periods of six weeks each as well as on several shorter cruises of approx. six to ten days in the North Sea (August 2009, July 2010, September 2010). During these cruises, the system was further optimized and tested. One continuous dataset from 13 July to 19 July 2010 generated in the North Sea is presented here (Fig. 8). During that period of continuous operation more than 3000 measurements were carried out at a rate of about  $1.5 \text{ min}^{-1}$ . The program was only interrupted during the washing times of the FerryBox (once a day) and for validation measurements. Approx. 5% of the data were rejected due to high regression errors during the correction for indicator perturbation or high temperature fluctuations of the sample caused by interruptions of the sample flow.

For comparison purposes the pH data of this system are converted from  $25^\circ\text{C}$  to in-situ temperature using R (R Development Core Team, 2011) and Seacarb (Lavigne and Gattuso, 2010) and plotted along with FerryBox data generated by a glass electrode. The glass electrode was chosen for comparison purposes because up to now it is the only operational commercially available system suitable for FerryBox integration. The comparison is however limited to qualitative aspects as the accuracy and stability of these electrodes is very limited. FerryBox pH data (glass electrode: NBS scale) is converted to total scale using Seacarb and activity coefficients from Dickson and Millero (1987). Here only a period of 24 h is plotted to avoid an excessively complex graph (Fig. 8). The glass electrode is part of the flow-through system of the FerryBox. The system provides flow rates of  $14 \text{ L min}^{-1}$  and measures at near to in-situ conditions. A slight temperature uncertainty of  $\pm 0.2^\circ\text{C}$  has to be considered because the sample water passes 6 m of tubing (30 mm i.d.) before entering the measuring system.

### Spectrophotometric underway pH determination

S. Aßmann et al.

Title Page

Abstract

Introduction

Conclusions

References

Tables

Figures



Back

Close

Full Screen / Esc

Printer-friendly Version

Interactive Discussion



**Spectrophotometric  
underway pH  
determination**

S. Aßmann et al.

Title Page

Abstract

Introduction

Conclusions

References

Tables

Figures

◀

▶

◀

▶

Back

Close

Full Screen / Esc

Printer-friendly Version

Interactive Discussion



The glass electrode is calibrated once every seven days during a cruise using standard NBS buffers at pH 7 and 9 from Metrohm. In Fig. 9b on 16 July there is a step in the differences between both pH traces indicating such a calibration point. It has to be mentioned that up to that point calibration of the electrode had been carried out more than a week earlier. This step illustrates the problems connected to potentiometric pH measurements such as liquid junction drift or problems with the reference electrode.

Figure 9 provides an overview of the pH measurements during a six day cruise in the North Sea and shows the high variability in this area. The high variability is caused by nutrient rich water bodies, primary production, respiration, tidal cycles and fresh water impact of rivers. Both sensors show the same behavior over the whole range of temperatures (15 to 21 °C, Fig. 9c) and salinities (29 to 35 psu, Fig. 9d) during the seven days. There are two larger variations in the differences of the two sensors on 17 July and in the very end of the cruise due to problems with the water sample feeding. During the time from 17 July to 19 July the distribution of the differences are smaller than before (i.e., 14 July to 17 July) due to lower pH gradients during this period. This can be explained with slight mismatches in time which could not be fully eliminated as well as a slightly different time constant of the sensors itself. Hence higher gradients in the water composition lead to higher differences of both sensors.

Even after calibrating the pH electrode on 16 July there is still an offset of  $-0.04$  pH units which is within the specification of the electrode. This demonstrates the problem when using pH buffers with low ionic strength and different water matrices. The structure in the offset between electrode and optical pH determination (e.g. the slight decrease in offset on 13 July and the slight increase between 14 July and 16 July) is caused by the drift of the pH electrode which can be explained with changes in the structure of the glass membrane due to aging and fouling. These changes are unavoidable with present commercially available systems. The presented data show that a combination of a glass electrode with an indicator based optical system may be even better suited for highly dynamic systems like the North Sea and its coast. It has been

shown that the glass electrode is stable for at most one day (Tishchenko et al., 2011) and needs to be calibrated according to this time range e.g. using an optical system. This leads to lower indicator consumption for long-term deployments without losing any temporal information. Moreover the electrode data is more reliable in salinities and temperatures outside the range of the specified correction functions of mCP (20 to 30 °C and 30 to 37 psu) and outside of the pH range of mCP.

### 4.3 Size and cost

No attempt was made to further optimize the system size. Nevertheless the presented system is very portable and much smaller than comparable systems with similar features (e.g., Friis et al., 2004). No water bath is needed, which reduces all related problems (size and handling). The whole system consists of three units not including the computer. The fluid handling system has a volume of 13 L, the electronics box (including the spectrometer) is about 9 L and the two programmable power supplies have a combined volume of 9 L. For an integration into an automated water measurement system some simple size optimizations would lead to a system about half that size.

While the components of the system add up to total costs of about 8000 € including the mini spectrometer (4000 €), syringe pump (300 €), peristaltic pump (1400 €), electronics for temperature control (1200 €), computer and miscellaneous components (1100 €), the running costs are low. Only one temperature sensor has to be calibrated. All other values are relative and do not require calibration. Maintenance consists of changing the syringes (once during a R/V *Polarstern* cruise of six weeks), refilling the indicator solution (1.5 L is enough for more than six weeks at a measurement frequency of 4 min<sup>-1</sup>) and cleaning the cuvette (once after six weeks).

A more extensive account of expense budgeting is beyond the scope of this report. The costs given above are those for building a replicate as a researcher, not as a manufacturer.

## Spectrophotometric underway pH determination

S. Aßmann et al.

Title Page

Abstract

Introduction

Conclusions

References

Tables

Figures



Back

Close

Full Screen / Esc

Printer-friendly Version

Interactive Discussion



## 4.4 Reliability

The system was optimized during several cruises in the North Sea as well as in the Atlantic Ocean. Especially the addition of the check valve was a minor but extremely important improvement for the stability of the pH determination. During all cruises the system was running very stable if a stable sample flow was provided. Air bubbles in the optical path cause problems and affect the precision of the result but do not change the pH value itself.

Spectral changes in the sample are compensated by the blank measurements prior to each injection. It is assumed that the sample does not change significantly during one measurement routine of less than 1 min. Optical changes due to light scattering caused by particles are thus only caused by the dye itself. These can be eliminated by filtering the stock solution using a filter with pores smaller than 0.4  $\mu\text{m}$ . As a result no drift of the baseline occurs and a drift correction at a non-absorbing wavelength can be omitted.

Another issue which has to be accounted for is fouling. The fouling actually only has an effect on the intensity of light which reaches the detector and therefore does not change the result of the measurement. But it has an impact on the precision. All FerryBox systems have a cleaning procedure which is run at least once a day. A first step is rinsing the whole system with fresh water. Afterwards sulfuric acid is added up to pH = 2 and finally oxalic acid is added into another fresh-water cleaning cycle to clean up oxidation products like corrosion of steel. This cleaning cycle also cleans the whole fluid path of the pH analyzer which also includes the optical path. No further cleaning procedures are necessary.

OSD

8, 1339–1367, 2011

### Spectrophotometric underway pH determination

S. Aßmann et al.

Title Page

Abstract

Introduction

Conclusions

References

Tables

Figures

⏪

⏩

◀

▶

Back

Close

Full Screen / Esc

Printer-friendly Version

Interactive Discussion





## 5 Conclusions

It has been shown that it is possible to build a small, robust and autonomous pH sensor in state-of-the-art CO<sub>2</sub>-system quality which is suitable for the integration into automated seawater measurement systems. The instrument described here reaches a precision of ±0.0007 pH units and an accuracy of better than 0.0018 pH units with a measurement frequency of up to 1 min<sup>-1</sup>.

The method used to adjust the sample temperature to 25 °C ± 0.006 °C is sophisticated but not complex and the whole system has proved to work reliably on ships. The integration into automated water measurement systems has been accomplished and provisions have been made for more demanding conditions, for example in the engine room of a voluntary observing ship.

The system has proven to be stable, reliable and accurate during all tests on board of research vessels. With these characteristics this device is ready to be used in combination with analyzers for dissolved inorganic carbon (DIC) or total alkalinity (TA) for a comprehensive characterization of the seawater carbon system.

*Acknowledgements.* This work was supported by the project OCEANET of the WGL Leibniz Association. We thank Friedhelm Schroeder who made this collaboration possible on the Helmholtz-Zentrum Geesthacht. Martina Gehrung provided FerryBox data such as in-situ salinity and temperature. We thank Peer Fietzek and Björn Fiedler for helpful discussions within the working group and Rüdiger Röttgers for providing his lab for spectrophotometric measurements. Special thanks belong to Karsten Friis, who gave precious advice especially in the early stages of this work.

OSD

8, 1339–1367, 2011

### Spectrophotometric underway pH determination

S. Aßmann et al.

Title Page

Abstract

Introduction

Conclusions

References

Tables

Figures

⏪

⏩

◀

▶

Back

Close

Full Screen / Esc

Printer-friendly Version

Interactive Discussion



## References

- Bellerby, R. G. J., Olsen, A., Johannessen, T., and Croot, P.: A high precision spectrophotometric method for on-line shipboard seawater pH measurements: the automated marine pH sensor (AMpS), *Talanta*, 56, 61–69, doi:10.1016/S0039-9140(01)00541-0, 2002. 1341
- 5 Clayton, T. D. and Byrne, R. H.: Spectrophotometric seawater pH measurements: total hydrogen ion concentration scale calibration of m-cresol purple and at-sea results, *Deep-Sea Res. Pt. I*, 40, 2115–2129, doi:10.1016/0967-0637(93)90048-8, 1993. 1341, 1343, 1349
- DelValls, T. A. and Dickson, A. G.: The pH of buffers based on 2-amino-2-hydroxymethyl-1,3-propanediol (tris) in synthetic sea water, *Deep-Sea Res. Pt. I*, 45, 1541–1554, doi:10.1016/S0967-0637(98)00019-3, 1998. 1343
- 10 Dickson, A. G.: pH scales and proton-transfer reactions in saline media such as sea water, *Geochim. Cosmochim. Ac.*, 48, 2299–2308, doi:10.1016/0016-7037(84)90225-4, 1984. 1342
- Dickson, A. G.: The measurement of sea water pH, *Mar. Chem.*, 44, 131–142, doi:10.1016/0304-4203(93)90198-W, 1993. 1350
- 15 Dickson, A. G. and Millero, F. J.: A comparison of the equilibrium constants for the dissociation of carbonic acid in seawater media, *Deep-Sea Res. Pt. I*, 34, 1733–1743, doi:10.1016/0198-0149(87)90021-5, 1987. 1351
- Dickson, A. G., Sabine, C. L., and Christian, J. R.: Guide to best practices for ocean CO<sub>2</sub> measurements, *PICES Special Publication 3*, p. 191, 2007. 1343, 1344, 1350, 1365
- 20 Doney, S. C., Fabry, V. J., Feely, R. A., and Kleypas, J. A.: Ocean acidification: The other CO<sub>2</sub> problem, *Annu. Rev. Mar. Sci.*, 1, 169–192, doi:10.1146/annurev.marine.010908.163834, 2009. 1341
- Dore, J. E., Lukas, R., Sadler, D. W., Church, M. J., and Karl, D. M.: Physical and biogeochemical modulation of ocean acidification in the Central North Pacific, *P. Natl. Acad. Sci. USA*, 106, 12235–40, doi:10.1073/pnas.0906044106, 2009. 1340
- 25 Frank, C. and Schroeder, F.: Using sequential injection analysis to improve system and data reliability of online methods: determination of ammonium and phosphate in coastal waters, *J. Autom. Method. Manag.*, 2007, 49535, doi:10.1155/2007/49535, 2007. 1347
- 30 Friis, K., Körtzinger, A., and Wallace, D. W. R.: Spectrophotometric pH measurement in the ocean: requirements, design, and testing of an autonomous charge-coupled device detector system, *Limnol. Oceanogr.-Meth.*, 2, 126–136, doi:10.4319/lom.2004.2.126, 2004. 1342,

## Spectrophotometric underway pH determination

S. Aßmann et al.

Title Page

Abstract

Introduction

Conclusions

References

Tables

Figures



Back

Close

Full Screen / Esc

Printer-friendly Version

Interactive Discussion



Lavigne, H. and Gattuso, J. P.: Seacarb: seawater carbonate chemistry with R. R package version 2.3. 3, Software, 2010. 1351

Liu, X., Wang, Z. A., Byrne, R. H., Kaltenbacher, E. A., and Bernstein, R. E.: Spectrophotometric measurements of pH in-Situ: laboratory and field evaluations of instrumental performance, *Environ. Sci. Tech.*, 40, 5036–5044, doi:10.1021/es0601843, 2006. 1341

Liu, X., Patsavas, M. C., and Byrne, R. H.: Purification and characterization of metacresol purple for spectrophotometric seawater pH measurements., *Environ. Sci. Tech.*, doi:10.1021/es200665d, 2011. 1350

Martz, T. R., Carr, J. J., French, C. R., and DeGrandpre, M. D.: A submersible autonomous sensor for spectrophotometric pH measurements of natural waters, *Anal. Chem.*, 75, 1844–1850, doi:10.1021/ac020568l, 2003. 1341, 1347

Martz, T. R., Connery, J. G., and Johnson, K. S.: Testing the Honeywell Durafet for seawater pH applications, *Limnol. Oceanogr.-Meth.*, 8, 172–184, doi:10.4319/lom.2010.8.172, 2010. 1341

Millero, F. J.: The marine inorganic carbon cycle, *Chem. Rev.*, 107, 308–41, doi:10.1021/cr0503557, 2007. 1340

Milne, G. W. A.: Gardner's Commercially Important Chemicals: Synonyms, Trade Names, and Properties, John Wiley & Sons, doi:10.1002/0471736627.ch1, 2005. 1343

Nakano, Y., Kimoto, H., Watanabe, S., Harada, K., and Watanabe, Y. W.: Simultaneous vertical measurements of in situ pH and CO<sub>2</sub> in the sea using spectrophotometric profilers, *J. Oceanogr.*, 62, 71–81, doi:10.1007/s10872-006-0033-y, 2006. 1341

Petersen, W., Petschatnikov, M., Schroeder, F., and Colijn, F.: FerryBox systems for monitoring coastal waters, *Elsev. Oceanogr. Serie.*, 69, 325–333, doi:10.1016/S0422-9894(03)80052-1, 2003. 1342, 1345

Petersen, W., Petschatnikov, M., Wehde, H., and Schroeder, F.: FerryBox – Real-Time Monitoring of Water Quality by Ferryboats, *EREM (Environmental Research, Engineering and Management)*, 3, 12–17, 2005. 1349

R Development Core Team: R: A Language and Environment for Statistical Computing, Vienna, Austria, R Foundation for Statistical Computing, 2011. 1351

Ramette, R. W., Culberson, C. H., and Bates, R. G.: Acid-base properties of tris(hydroxymethyl)aminomethane (Tris) buffers in sea water from 5 to 40 °C, *Anal. Chem.*, 49, 867–870, doi:10.1021/ac50014a049, 1977. 1343

## Spectrophotometric underway pH determination

S. Aßmann et al.

Title Page

Abstract

Introduction

Conclusions

References

Tables

Figures

◀

▶

◀

▶

Back

Close

Full Screen / Esc

Printer-friendly Version

Interactive Discussion



**Spectrophotometric  
underway pH  
determination**

S. Aßmann et al.

Title Page

Abstract

Introduction

Conclusions

References

Tables

Figures



Back

Close

Full Screen / Esc

Printer-friendly Version

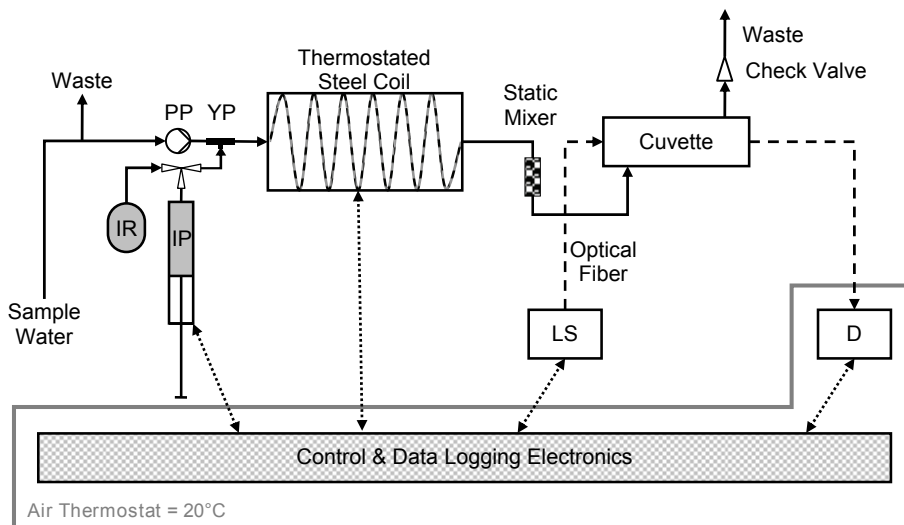
Interactive Discussion



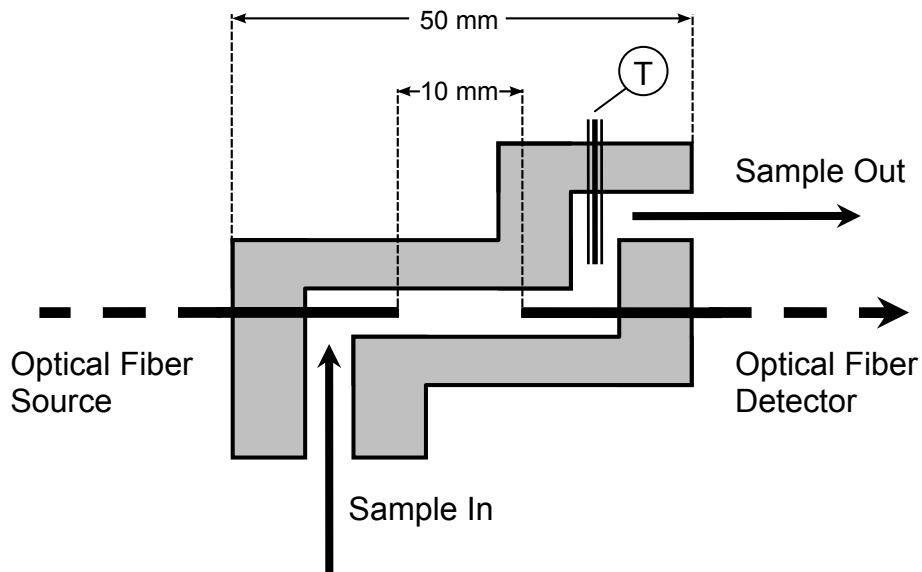
- Raven, J., Caldeira, K., Elderfield, H., Hough-Guldberg, O., Liss, P., Riebesell, U., Shepherd, J., Turley, C. M., and Watson, A.: Ocean acidification due to previous termincreasing atmospheric carbon dioxide, The Royal Society Policy Document, 12, 68, 2005. 1343
- Sabine, C. L., Feely, R. A., Gruber, N., Key, R. M., Lee, K., Bullister, J. L., Wanninkhof, R., Wong, C. S., Wallace, D. W. R., Tilbrook, B., Millero, F. J., Peng, T.-H., Kozyr, A., Ono, T., and Rios, A. F.: The oceanic sink for anthropogenic CO<sub>2</sub>, Science, 305, 367–371, doi:10.1126/science.1097403, 2004. 1341
- Salim, S. G. R., Fox, N. P., Theocharous, E., Sun, T., and Grattan, K. T. V.: Temperature and nonlinearity corrections for a photodiode array spectrometer used in the field, Appl. Opt., 50, 866–875, doi:10.1364/AO.50.000866, 2011. 1342
- SCOR Working Group 75: Methodology for oceanic CO<sub>2</sub> measurements, UNESCO technical papers in marine science, 65, 1988. 1341
- Seidel, M. P., DeGrandpre, M. D., and Dickson, A. G.: A sensor for in situ indicator-based measurements of seawater pH, Mar. Chem., 109, 18–28, doi:10.1016/j.marchem.2007.11.013, 2008. 1341, 1342, 1349
- Tishchenko, P. Y., Kang, D.-J., Chichkin, R. V., Lazaryuk, A. Y., Wong, C. S., and Johnson, W. K.: Application of potentiometric method using a cell without liquid junction to underway pH Measurements in surface seawater, Deep-Sea Res. Pt. I, doi:10.1016/j.dsr.2011.05.002, 2011. 1353
- van Rossum, G.: Python Library Reference, Citeseer, Amsterdam, release 2. Edn., 1995. 1347
- Wang, Z. A., Liu, X., Byrne, R. H., Wanninkhof, R., Bernstein, R. E., Kaltenbacher, E. A., and Patten, J.: Simultaneous spectrophotometric flow-through measurements of pH, carbon dioxide fugacity, and total inorganic carbon in seawater, Anal. Chim. Acta, 596, 23–36, doi:10.1016/j.aca.2007.05.048, 2007. 1351
- Yao, W., Liu, X., and Byrne, R. H.: Impurities in indicators used for spectrophotometric seawater pH measurements: assessment and remedies, Mar. Chem., 107, 167–172, doi:10.1016/j.marchem.2007.06.012, 2007. 1350
- Zeebe, R. E. and Wolf-Gladrow, D. A.: CO<sub>2</sub> in Seawater: Equilibrium, Kinetics, Isotopes, vol. 65, Elsevier Science, 2001. 1342
- Zhang, H. and Byrne, R. H.: Spectrophotometric pH measurements of surface seawater at in-situ conditions: absorbance and protonation behavior of thymol blue, Mar. Chem., 52, 17–25, doi:10.1016/0304-4203(95)00076-3, 1996. 1341, 1349

**Spectrophotometric  
underway pH  
determination**

S. Aßmann et al.



**Fig. 1.** Overview of the spectrophotometric pH system. IR: Indicator Reservoir, PP: Peristaltic Pump, IP: Indicator Pump, YP: Y-piece, LS: Light Source, D: Detector. The steel coil is embedded in an aluminum body providing a temperature regulation of the continuous flow in the cuvette to  $25^{\circ}\text{C} \pm 0.006^{\circ}\text{C}$  ( $1\sigma$ ). The cuvette is isolated with polystyrene for protection from environmental temperature fluctuations.



**Fig. 2.** Design of the custom made cuvette. The length of the optical path between the two fiber probes is 10 mm. Each fiber has an overlap into the cuvette of 5 mm to minimize perturbations caused by air bubbles. T is a temperature sensor for direct sample measurements and temperature regulation of the sample.

**Spectrophotometric  
underway pH  
determination**

S. Aßmann et al.

Title Page

Abstract

Introduction

Conclusions

References

Tables

Figures

⏪

⏩

◀

▶

Back

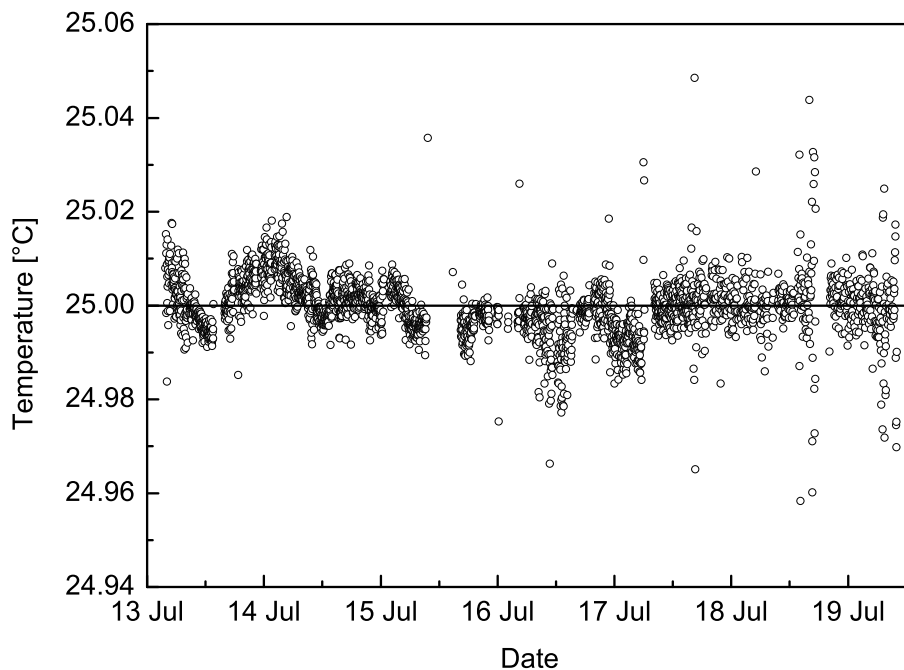
Close

Full Screen / Esc

Printer-friendly Version

Interactive Discussion





**Fig. 3.** Tightly controlled sample temperature at  $25\text{ °C} \pm 0.006\text{ °C}$  detected in the cuvette which is a main criterion for precise pH measurements. Temperature regulation is realized by Peltier elements in a preceding heat exchanger (see Fig. 1). Data are from a six-day period during HE331 cruise in July 2010 on R/V *Heincke*.

**Spectrophotometric  
underway pH  
determination**

S. Aßmann et al.

Title Page

Abstract

Introduction

Conclusions

References

Tables

Figures

◀

▶

◀

▶

Back

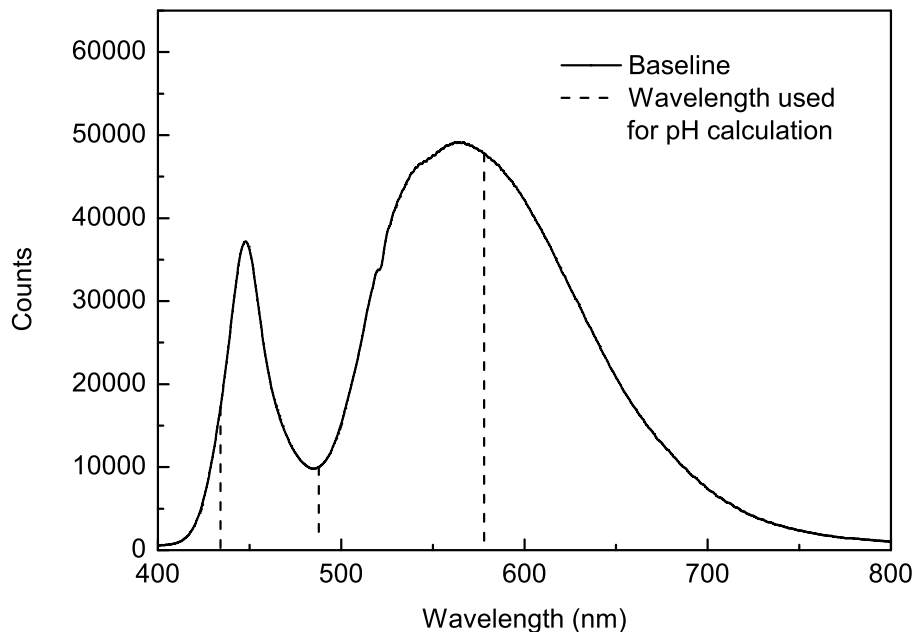
Close

Full Screen / Esc

Printer-friendly Version

Interactive Discussion





**Fig. 4.** Electrical counts of the emission spectrum of the ultra bright white LED taken with the CCD spectrometer during shipboard operation through seawater. The marked measurement wavelengths 434 nm and 578 nm are used for pH calculation and 487.6 nm (isosbestic point of mCP) is used for detection of the indicator dye concentration.

**Spectrophotometric underway pH determination**

S. Aßmann et al.

Title Page

Abstract

Introduction

Conclusions

References

Tables

Figures

⏪

⏩

◀

▶

Back

Close

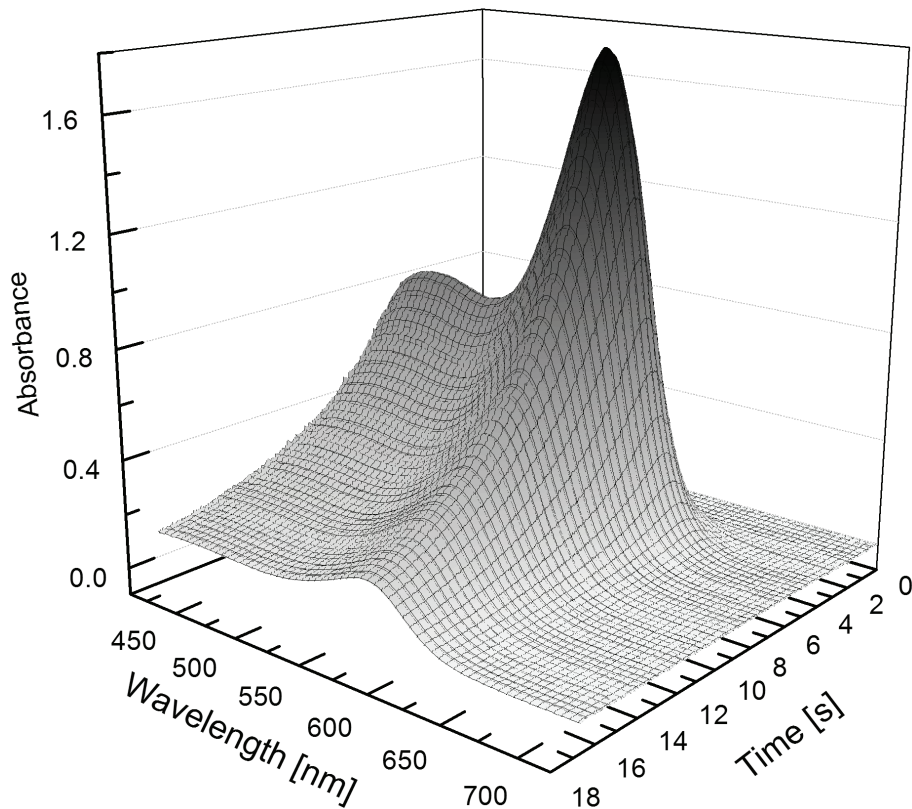
Full Screen / Esc

Printer-friendly Version

Interactive Discussion







**Fig. 5.** Dilution curve running through the cuvette after indicator injection into a continuous sample flow and the recorded spectra. The smooth backward flank of the concentration peak is used for calculation of the perturbation-free pH value. For this more than 200 spectra are available (compare Fig. 6).

**Spectrophotometric  
underway pH  
determination**

S. Aßmann et al.

Title Page

Abstract

Introduction

Conclusions

References

Tables

Figures

⏪

⏩

◀

▶

Back

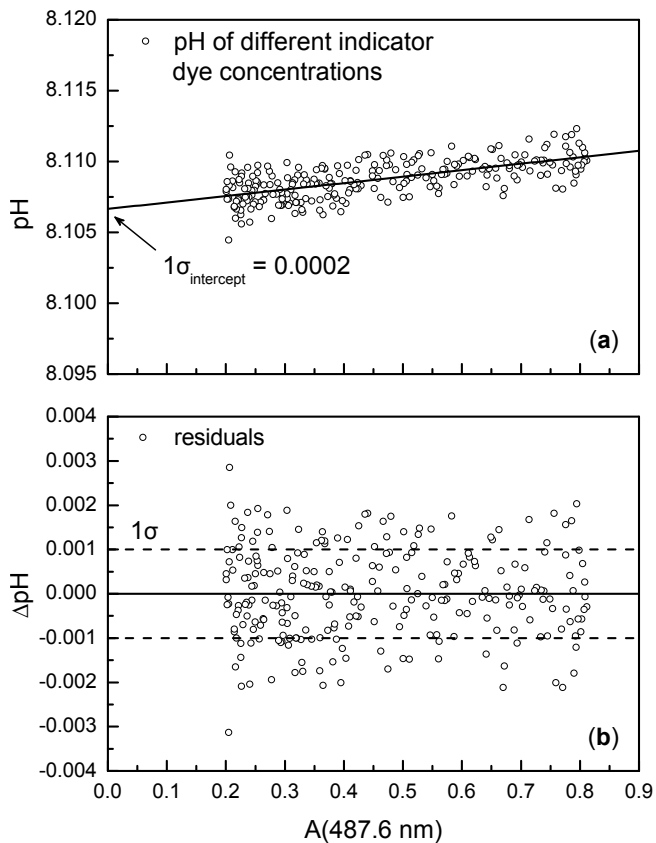
Close

Full Screen / Esc

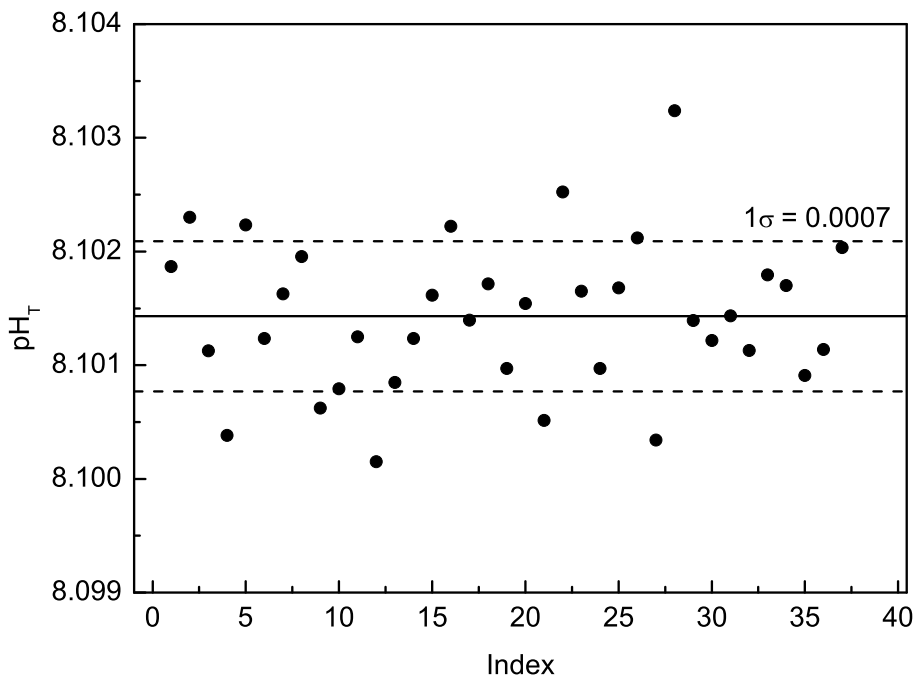
Printer-friendly Version

Interactive Discussion





**Fig. 6.** Example plot for pH versus absorbance of mCP at 487.6 nm. The curve in (a) represents a linear regression and extrapolation to zero indicator concentration. Slope =  $0.0046 \pm 0.0003$ ; axis intercept =  $8.1067 \pm 0.0002$ ;  $N = 258$ . The residuals are given in (b). Errors are given as  $1\sigma$  standard error.



**Fig. 7.** Repetition measurements of a TRIS buffer based on the recipe in Dickson et al. (2007). The mean pH value is 8.1014 with a  $1\sigma$  standard deviation of  $\pm 0.0007$ ,  $N = 37$ . Index is the consecutive number of the repetition measurements.

**Spectrophotometric  
underway pH  
determination**

S. Aßmann et al.

Title Page

Abstract

Introduction

Conclusions

References

Tables

Figures

◀

▶

◀

▶

Back

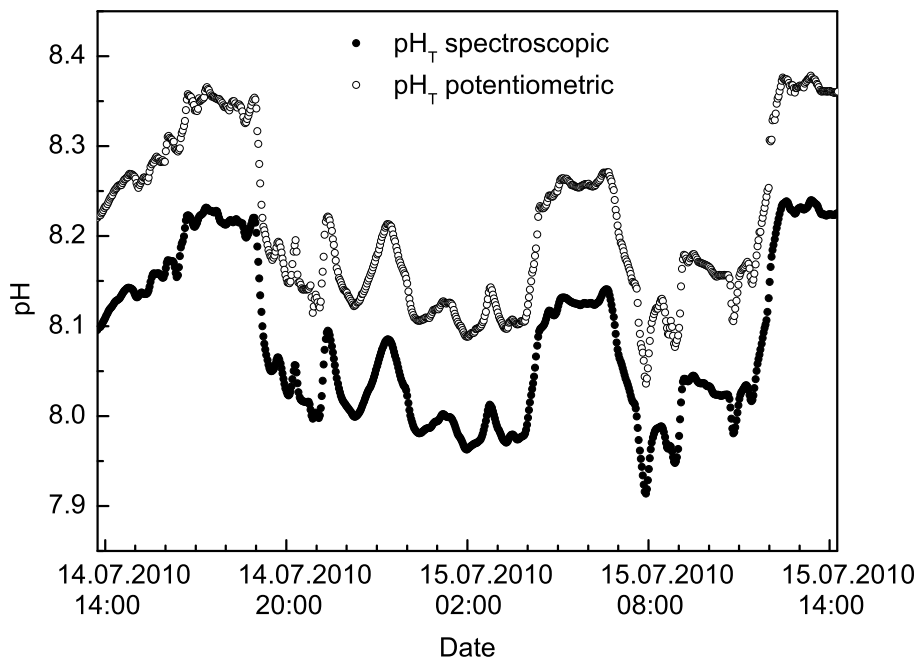
Close

Full Screen / Esc

Printer-friendly Version

Interactive Discussion

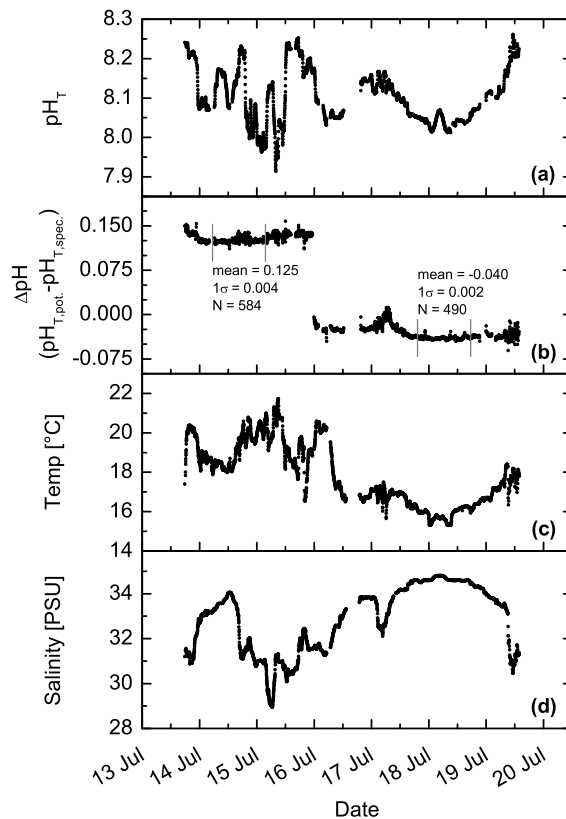




**Fig. 8.** Comparison of the optically and potentiometrically measured pH for a selected period of 24 h with intense pH variations. Both datasets are converted to the total pH scale at in-situ temperature. The average offset is 0.13 pH units. The last calibration of the glass electrode up to that point was more than a week earlier.

Spectrophotometric  
underway pH  
determination

S. Aßmann et al.



**Fig. 9.** In-situ data of a cruise in the North Sea from 13 July to 19 July 2010. **(a)** Optically measured  $\text{pH}_T$ . **(b)** Differences of potentiometric and spectrophotometric measured pH. A calibration of the glass electrode took place at 16 July. Before and after the calibration point, there are two sectors marked for which the mean and standard deviation is calculated. **(c)** Temperature measured in the FerryBox. **(d)** Salinity measured in the FerryBox.

Title Page

Abstract

Introduction

Conclusions

References

Tables

Figures

◀

▶

◀

▶

Back

Close

Full Screen / Esc

Printer-friendly Version

Interactive Discussion

